

Strapping Requirements

A. 2"x24 gage strapping is to be attached to the top of the purlins, running continuous from eave to ridge, at each column line. If strapping is to be spliced, splice must occur over a purlin. Use four fasteners to attach the splice to the purlin.

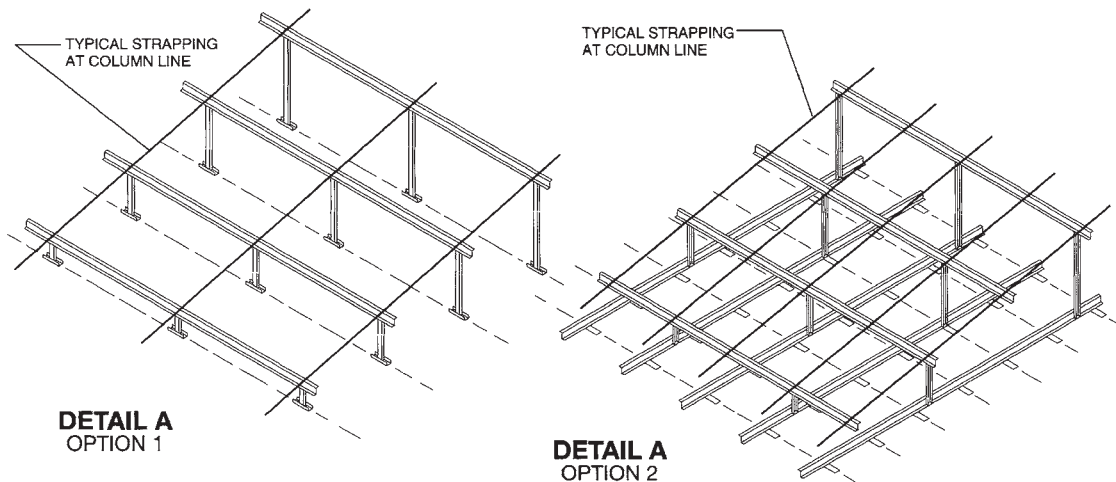

B. When a MBCI standing seam panel is used, purlin stabilization strapping is required at the top and bottom flanges of the retrofit purlin at a maximum of 5'-0" o.c. between column lines, if column spacing exceeds 5'-0" o.c.

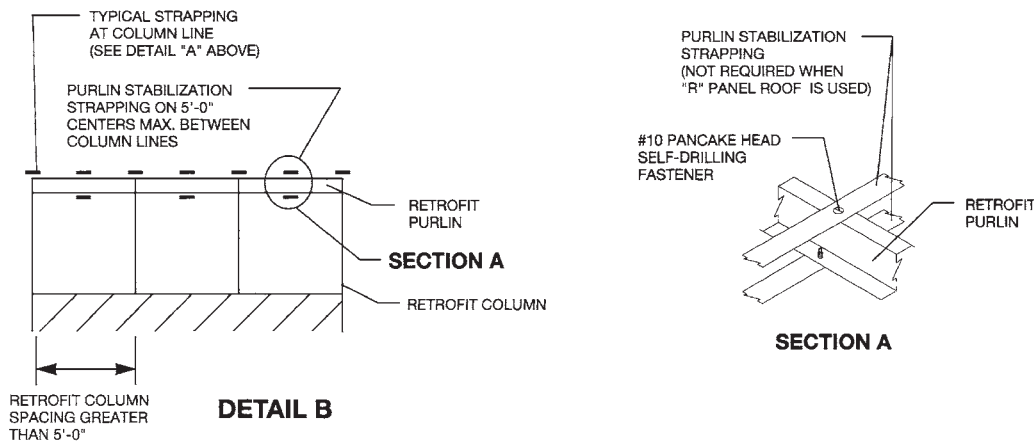

FIGURE 14.3 Bracing of retrofit purlins. (MBCI.)

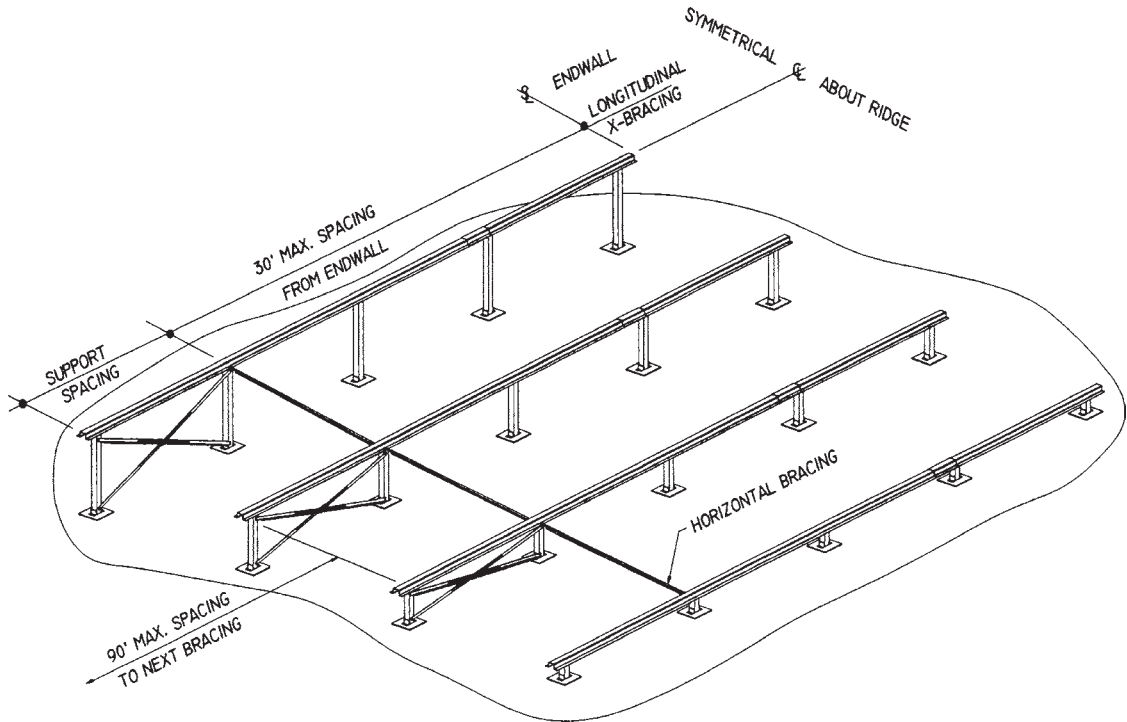

FIGURE 14.4 Typical longitudinal bracing layout for slope buildup. (For clarity, bracing in the transverse direction is not shown.) (Butler Manufacturing Co.)

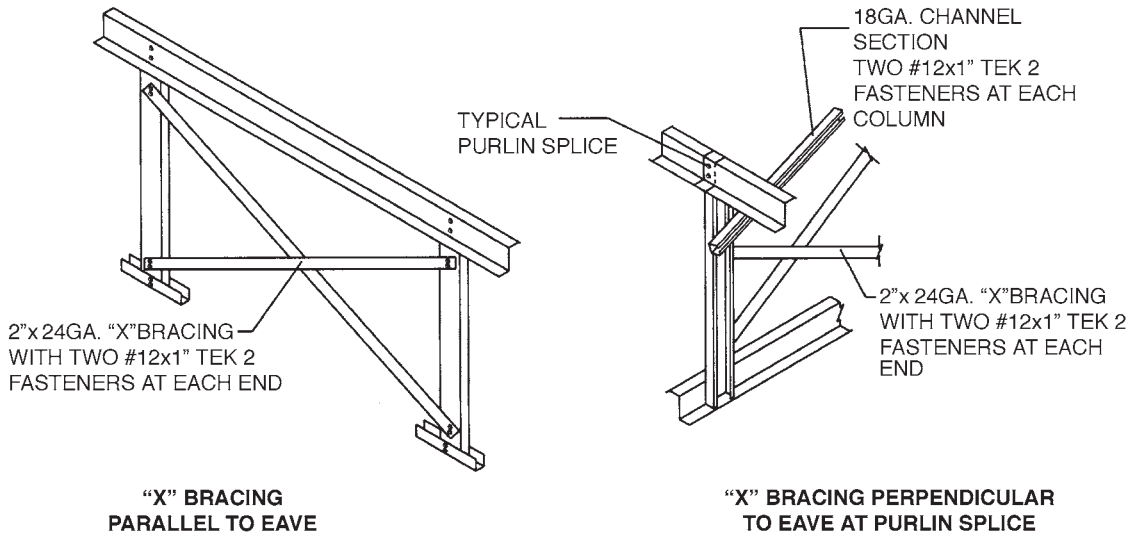

FIGURE 14.5 Typical cross-bracing details. (MBCI.)